

# HEAT~WAVE

## INDIRECT WATER HEATERS

### HW – SERIES

## INSTALLATION GUIDE



Heat~Wave Indirect Water Heaters 2546 Iona Road Belfast PEI Canada C0A 1A0  
Tel: 1.902.659.2424 - Fax: 1.902.659.2800 - Email: [info@secheatexchangers.com](mailto:info@secheatexchangers.com)

## **INSTALLATION AND OPERATING MANUAL FOR HEAT~WAVE INDIRECT WATER HEATERS**

INSTALLATION OF HW INDIRECT WATER HEATERS CONSISTS OF THE FOLLOWING STEPS:

1. POSITION THE TANK FOR EASE OF INSTALLATION AND SERVICE.
2. COLD WATER SUPPLY: A 3/4" BRASS DRAIN VALVE SHOULD BE INSTALLED ON THE BOTTOM CONNECTION LABELED "COLD IN". A SHUTOFF VALVE BETWEEN THE TANK AND WATER SUPPLY IS RECOMMENDED. A BACKFLOW CHECK VALVE SHOULD BE INSTALLED IF REQUIRED BY STATE OR LOCAL CODE.
3. HOT WATER SUPPLY CONNECTION SHOULD BE MADE TO THE TOP NIPPLE LABELED "HOT OUT". WE STRONGLY RECOMMEND THE USE OF COPPER PIPING.
4. INSTALL 3/4" TEMPERATURE AND PRESSURE RELIEF VALVE IN THE OPENING MARKED "T&P".

**CAUTION** TO REDUCE THE RISK OF EXCESSIVE PRESSURES AND TEMPERATURES, INSTALL TEMPERATURE AND PRESSURE PROTECTIVE EQUIPMENT REQUIRED BY LOCAL CODES, BUT NO LESS THAN A COMBINATION TEMPERATURE AND PRESSURE RELIEF VALVE CERTIFIED BY A NATIONALLY RECOGNIZED TESTING LABORATORY THAT MAINTAINS PERIODIC INSPECTION OF LISTED EQUIPMENT OR MATERIALS, AS MEETING THE REQUIREMENT'S FOR "RELIEF VALVES AND AUTOMATIC SHUTOFF DEVICES FOR HOT WATER SYSTEMS", ANSI Z21.22-1986. THIS VALVE MUST BE MARKED WITH A MAXIMUM SET PRESSURE NOT TO EXCEED THE MAX. WORKING PRESSURE. THE VALVE MUST BE ORIENTED, PROVIDED WITH TUBING, OR OTHERWISE INSTALLED SO THAT DISCHARGE CAN EXIT ONLY WITHIN 6 INCHES ABOVE, OR AT ANY DISTANCE BELOW, THE STRUCTURAL FLOOR, AND CANNOT CONTACT ANY ELECTRICAL PART. THE DISCHARGE OPENING MUST NO BE BLOCKED OR REDUCED IN SIZE UNDER ANY CIRCUMSTANCES.

5. FILL THE TANK WITH WATER. WHILE FILLING THE TANK, A HOT WATER FAUCET NEAR THE TANK SHOULD REMAIN OPEN UNTIL THE TANK IS FULL, AND STEADY STREAM OF WATER IS FLOWING THROUGH THE FAUCET. SHUT OFF THE FAUCET, AND CHECK FOR LEAKS IN THE SYSTEM.

6. BOILER AND HEAT EXCHANGER CONNECTION: IT IS RECOMMENDED THAT 1" PIPING BE USED. HEAT EXCHANGER FITTINGS ARE 1" MALE. IT IS RECOMMENDED THAT SWEAT CONNECTIONS BE DONE AWAY FROM THE TANK, TO PREVENT DAMAGE TO THE TANK JACKET. DIRECT THE FLOW OF WATER FROM THE BOILER TO THE UPPER END OF THE HEAT EXCHANGER LABELED "BOILER IN", AND BACK TO THE BOILER FROM THE CONNECTION LABELED "BOILER OUT".

7. WIRING THE TANK CONTROL: ALL HEAT WAVE TANKS CAN BE EQUIPPED WITH AN AQUASTAT FOR TEMPERATURE CONTROL (OPTIONAL). THE AQUASTAT SUPPLIED WITH THE TANK IS PRESET AT THE FACTORY FOR 140 DEGREES FAHRENHEIT. TO CONNECT THE AQUASTAT, REMOVE THE FRONT COVER, AND FOLLOW THE WIRING DIAGRAM PROVIDED WITH THE AQUASTAT. ELECTRICAL WIRING MUST COMPLY WITH STATE AND LOCAL CODES.

8. WHEREVER POSSIBLE, TANK PIPING SHOULD BE INSTLLED WITH UNIONS AND SHUT-OFF BALL VALVES FOR EASE OF SERVICE AND MAINTENANCE.

**NOTE:** THE USE OF COPPER PIPE/TUBE IS RECOMMENDED FOR HEAT~WAVE INSTALLATIONS.

**Heat~Wave Indirect Water Heaters 2546 Iona Road Belfast PEI Canada C0A 1A0  
Tel: 1.902.659.2424 - Fax: 1.902.659.2800 - Email: [info@secheatexchangers.com](mailto:info@secheatexchangers.com)**

# CIRCULATOR ZONING (PRIORITY)

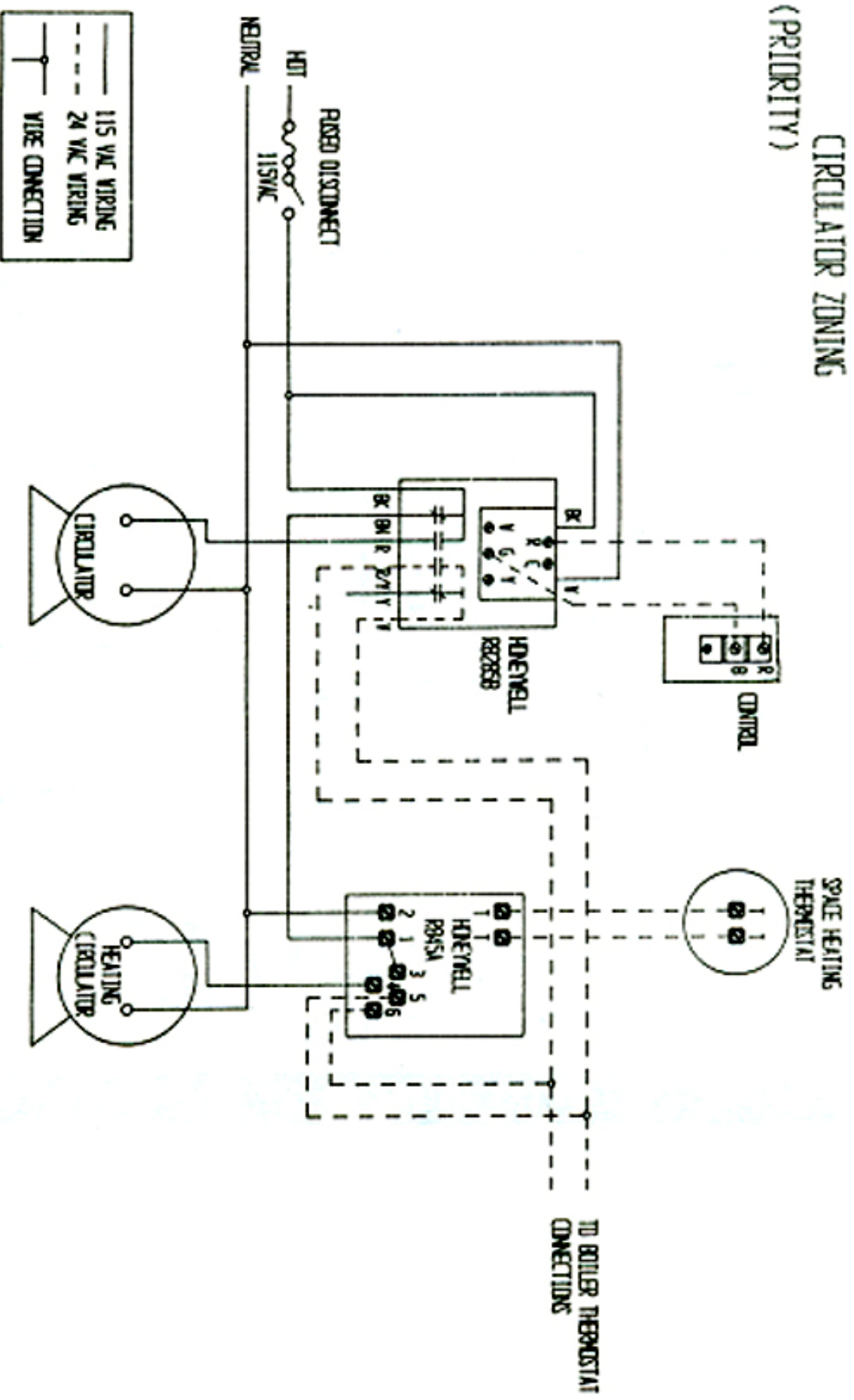

# CIRC. ZONE WIRING (NON-PRIORITY) USING HONEYWELL R845'S

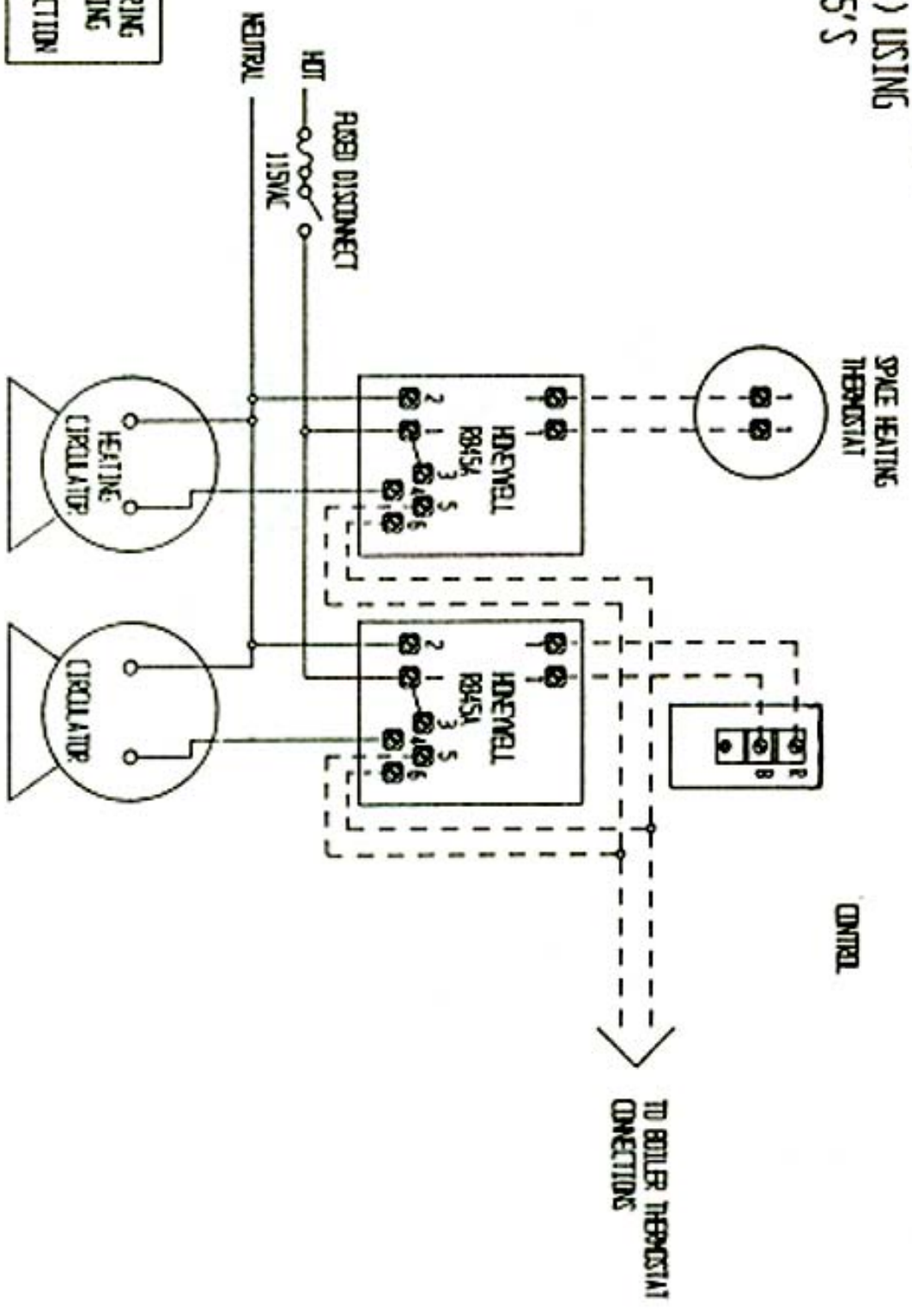
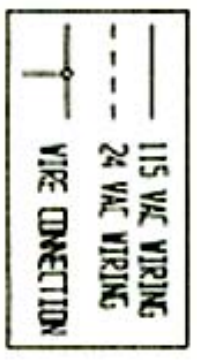

# ZONE VALVE WIRING (2-WAY VALVES, PRIORITY)

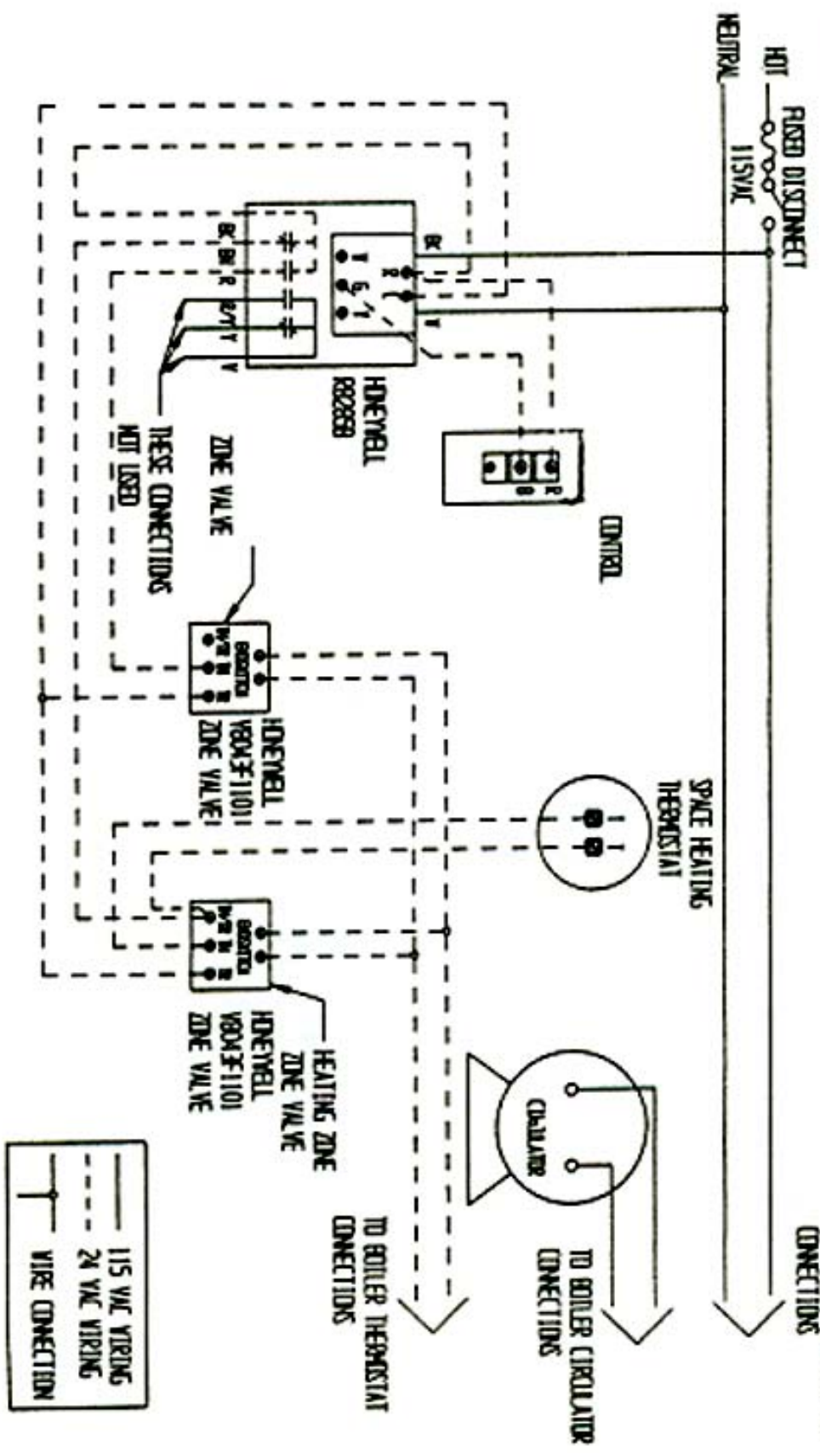

# ZONE VALVE WIRING (2-WAY VALVES, NON-PRIORITY)

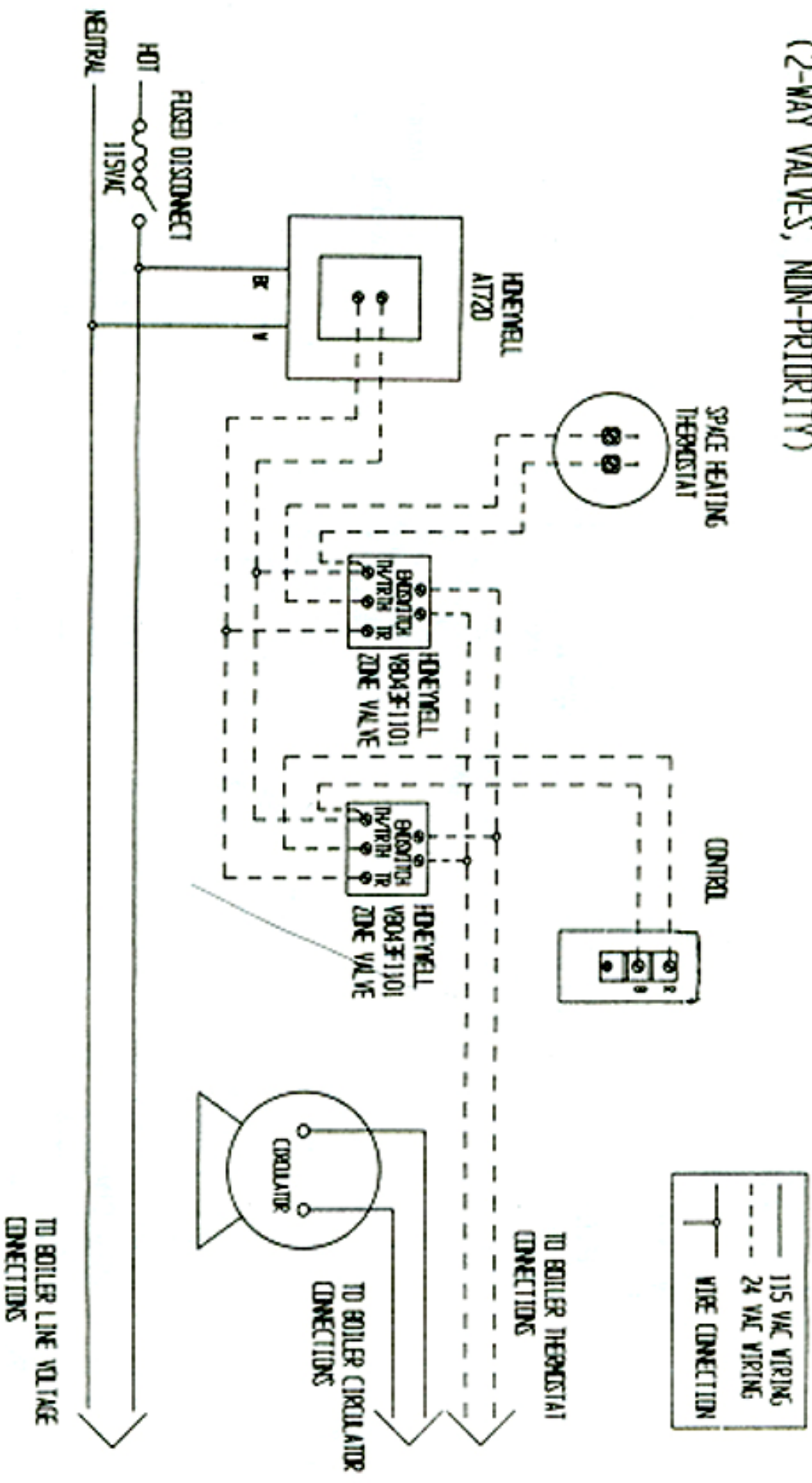

# ZONE VALVE WIRING (3-WAY VALVE, PRIORITY)

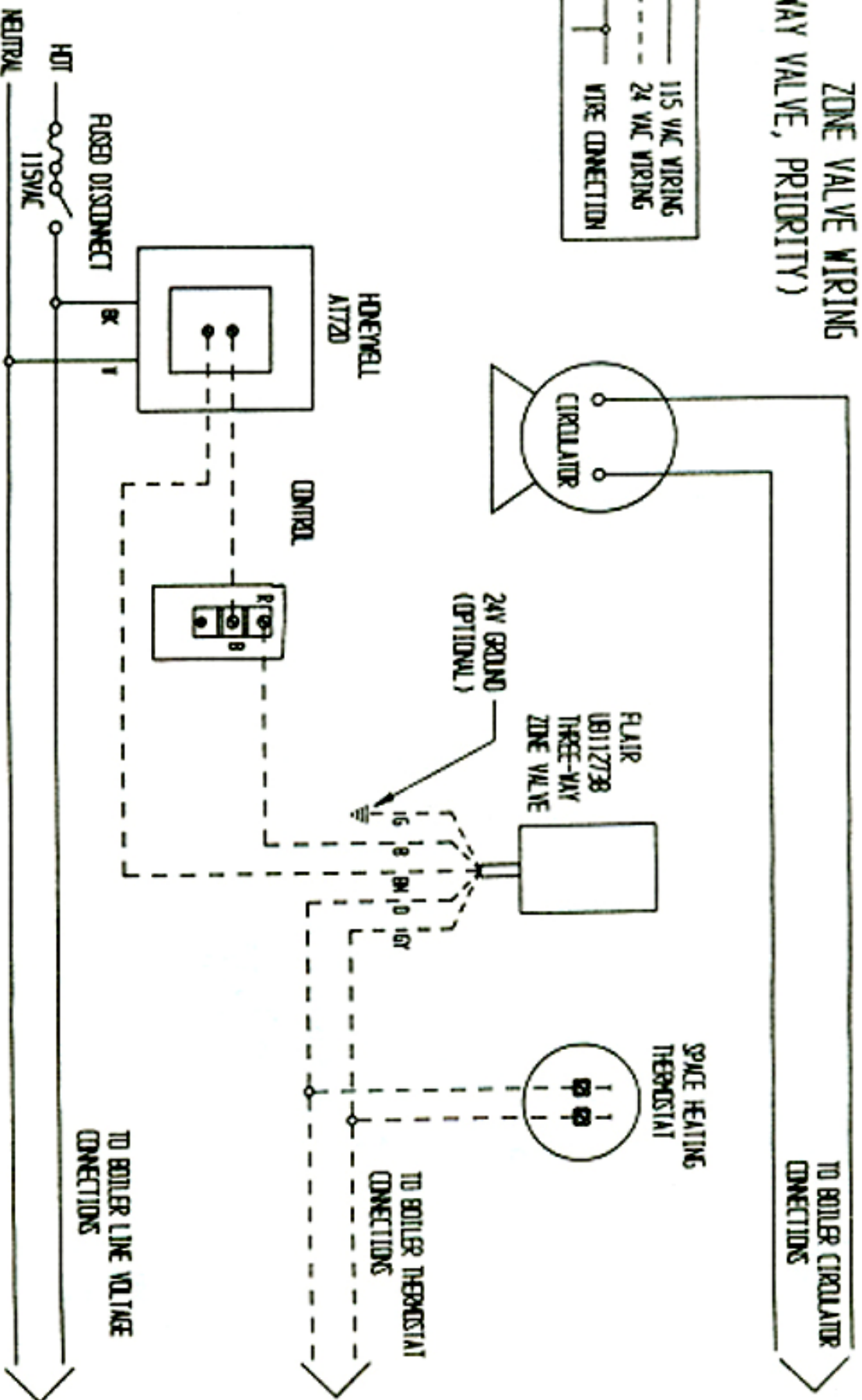
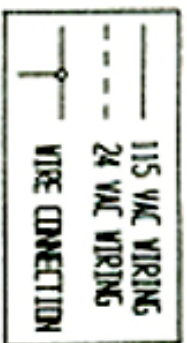

# DUAL CIRCULATOR SYSTEM

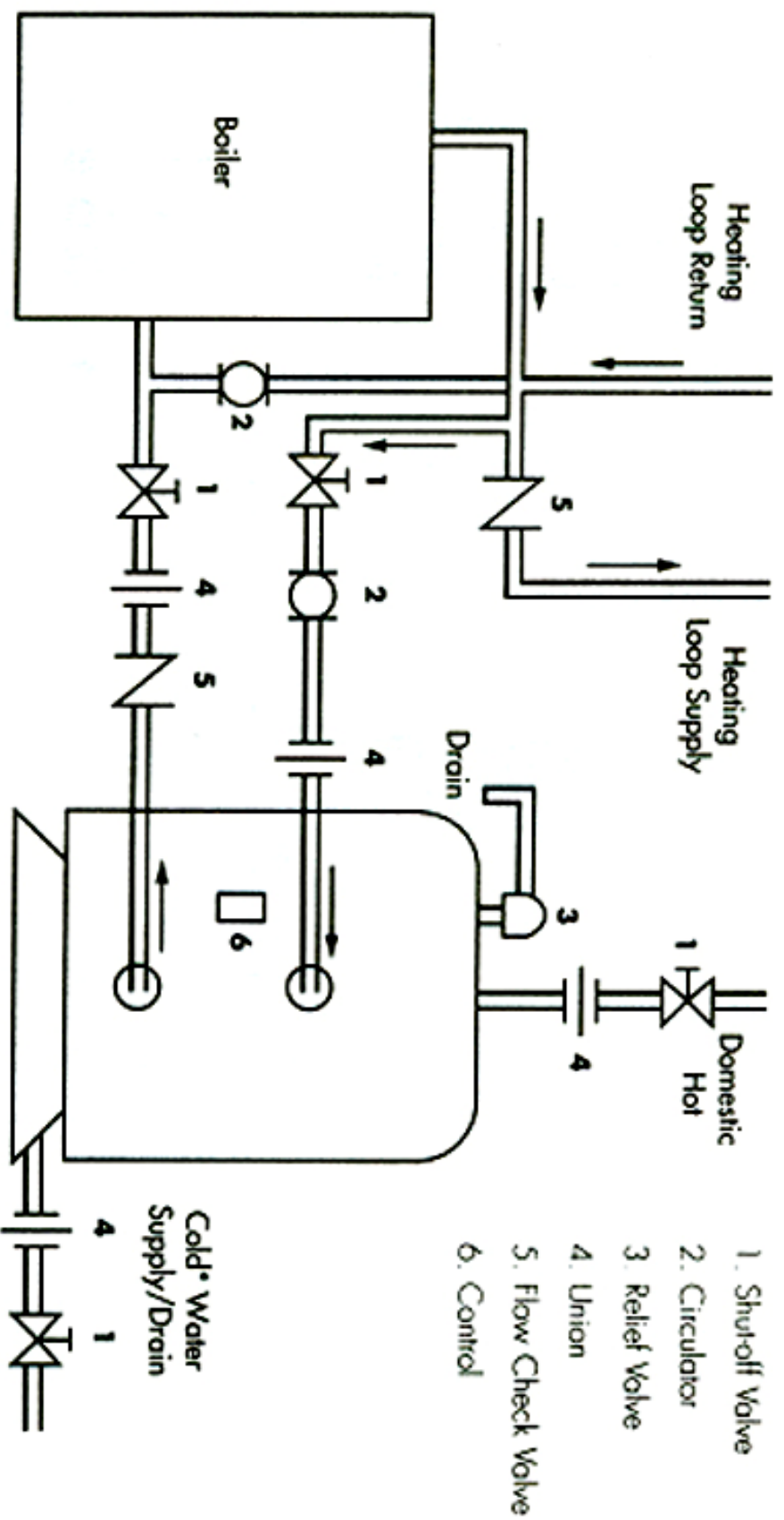

• If check valve is installed, odd thermal expansion tank.

MODEL	HW30	HW40	HW40L	HW50	HW60	HW80	HW115
Pump Capacity (gpm)	5	5	5	8	10	13	17
Loss in Feet	1.4	1.4	1.4	2.5	3.5	5.9	13
Capacity (gal.)	30	40	40	50	60	80	115
Boiler Output (MBH)	75	85	85	100	125	175	225
Output (gal.)							
First Hour	112	145	145	170	212	285	390
Continuous	91	115	115	135	167	233	300
Connections (inch)							
Domestic	3/4	3/4	3/4	3/4	3/4	1	1-1/2
Boiler	1	1	1	1	1	1	1
Re circulation	-	-	-	-	-	3/4	3/4
Dimensions (inch)							
Diameter	19.3	19.3	23.3	23.3	23.3	23.3	27.6
Height	46.6	59.7	42.4	50.4	58.4	74.4	76
Shipping Weight (lbs)	65	80	80	95	110	140	180
Test Pressure: 300 psi. Working Pressure: 150 psi.							

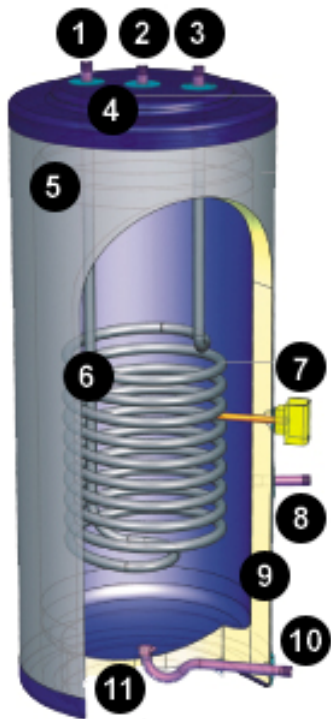

1. boiler water outlet
2. domestic water out (hot)
3. boiler water inlet
4. safety valve (t&p)
5. Jacket
6. stainless heating coil
7. temperature control
8. re-circulation
9. hi-density insulation
10. diffuser
11. domestic water inlet (cold)

Heat-Wave Indirect Water Heaters 2546 Iona Road Belfast PEI Canada C0A 1A0  
Tel: 1.902.659.2424 - Fax: 1.902.659.2800 - Email: [info@secheatexchangers.com](mailto:info@secheatexchangers.com)

## **WARRANTY DOES NOT COVER:**

1. Any component parts that are part of the indirect-fired water heater system but not furnished by HEAT~WAVE as part of the residential indirect-fired water heater.
2. This warranty does not cover expenses for removal or reinstallation. The homeowner will be responsible for the cost of removing and reinstalling the alleged defective part or its replacement and all labor and material connected therewith, and transportation to and from HEAT~WAVE.
3. This warranty cannot be considered as a guarantee of workmanship of an installer connected with the installation of the HEAT~WAVE indirect-fired water heater, or as imposing on HEAT~WAVE liability of any nature for unsatisfactory performance as a result of faulty workmanship in the installation, which liability is expressly disclaimed.
4. Any residential indirect-fired water heater installed in buildings other than one or two family dwelling units, unless they are buildings with individual indirect-fired water heaters for each dwelling unit.
5. Any indirect-fired water heater operated at **water temperatures over 200 F** and water pressure over 150 P.S.I.
6. Any failure or malfunction resulting from improper or negligent operation, accident, abuse (including freezing).
7. Any failure or malfunction resulting from failure to keep the tank full of potable water, free to circulate at all times and with the tank free of damaging water sediment or scale deposits.
8. Any indirect-fired water heater that is used for non-potable applications such as pool or process heating.
9. Any indirect-fired water heater that is installed in a residence containing any type of water softener system that is not installed and maintained in accordance with the manufacturer's specifications.
10. Any indirect-fired water heater that heats potable water with the following characteristics: dissolved chloride in excess of 60 PPM, measurable amounts of any compound containing chloride, or PH less than 6.0 or greater than 8.0.

## ***THE OWNER OR INSTALLER MUST:***

- 1. Have the storage tank assembly installed with a vacuum relief valve and temperature and pressure relief valve in accordance with local, state and federal codes and ordinances bearing the listing marks of the American Society of Mechanical Engineers (A.S.M.E.).**
- 2. Operate the storage assembly at pressure below that shown on the rating plate on pressure relief valve.**
- 3. Keep the storage tank and coil free of damaging scale deposits.**
- 4. Make provisions so if the storage tank or any component part or connection thereto should leak, the resulting flow of water will not cause damage to the area in which it is installed. A water heater temperature and pressure relief valve should be piped to the nearest drain in order to avoid damage in the event the valve is activated.**

## **HEAT~WAVE INDIRECT WATER HEATERS**

### **Customer Service:**

**Call: 1.800.335.6650 or 1.902.659.2424**

**Fax: 1-902-659-2800 or Email [info@secheatexchangers.com](mailto:info@secheatexchangers.com)**